



DRAWING APPROVAL

APPROVED **APPROVED AS CORRECTED**
DRAWING MUST BE APPROVED & SIGNED PRIOR TO FABRICATION & SHOP DRAWINGS

SIGNATURE: _____ DATE: _____

GRILL KIT DESIGN (\$7,654.75)
 COUNTERTOP, CLADDING ON 2 SIDES AND FRONT (GROUP 0 DEKTON)



DRAWN: D. BENNETT	PROJECT: GRILL KIT	
EMAIL: darcy@bennettpollio.com		A1
SCALE:		
DATE: 10/21/20	QUOTE #: TuClad	

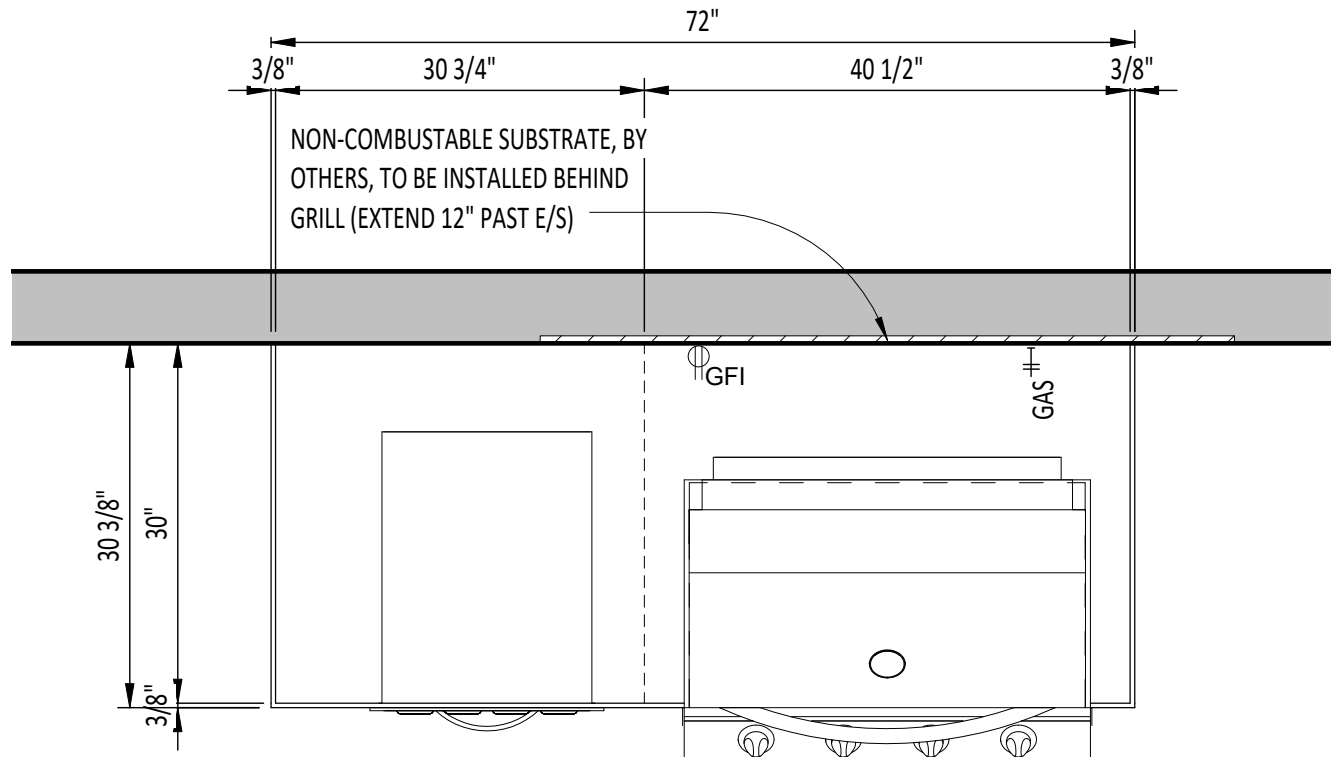

Jackson
Trash Bin
TRASH BIN PULLOUT

JACKSON 34" LUX GRILL
C/W 4 BURNERS &
ROTISSERIE (JLS700BI)

Jackson
BIDCOMBODOOR
31.25x22.63 COMBO
DOOR/DRAWER

1 KITCHEN PLAN
3/4" = 1'-0"

DRAWING APPROVAL

APPROVED APPROVED AS CORRECTED
DRAWING MUST BE APPROVED & SIGNED PRIOR TO FABRICATION & SHOP DRAWINGS

SIGNATURE: _____ DATE: _____



DRAWN: D. BENNETT

EMAIL: darcy@bennettpollio.com

SCALE: 3/4" = 1'-0"

DATE: 10/21/20

PROJECT: GRILL KIT

QUOTE #: TuClad

A2

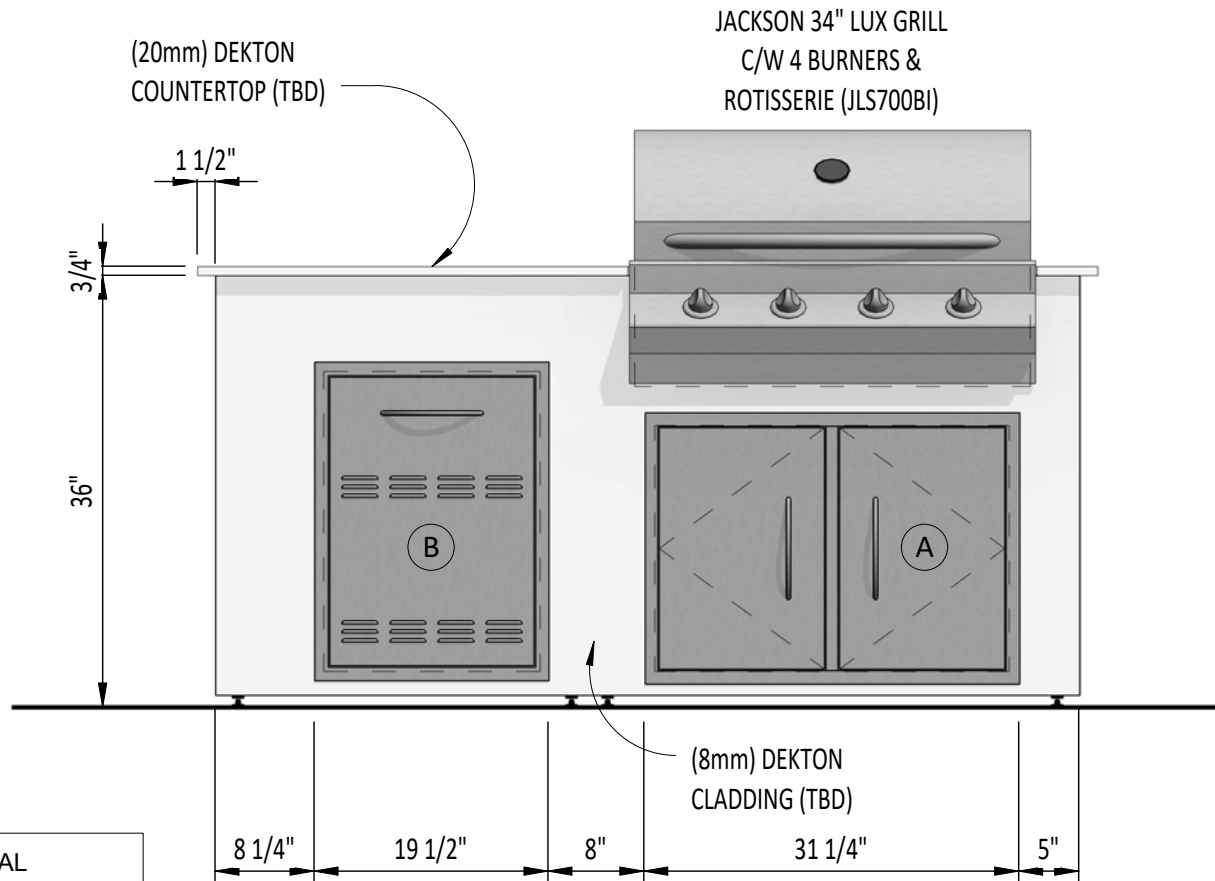

DRAWING APPROVAL

APPROVED APPROVED AS CORRECTED
DRAWING MUST BE APPROVED & SIGNED PRIOR TO FABRICATION & SHOP DRAWINGS

SIGNATURE: _____ DATE: _____



DRAWN: D. BENNETT

EMAIL: darcy@bennettpollio.com

SCALE: 3/4" = 1'-0"

DATE: 10/21/20

PROJECT: GRILL KIT

QUOTE #: TuClad

A3

CABINET ITEM LIST (LOCAL SUPPLIER CANADA OUTDOOR KITCHENS)			
MARK	BRAND	DESCRIPTION	MODEL
A	Jackson	31 1/4"x22 5/8" Combo Door/Drawer	BIDCOMBODOOR
B	Jackson	Pull Out Trash Bin Holder	Trash Bin

APPLIANCE SCHEDULE (LOCAL SUPPLIER CANADA OUTDOOR KITCHENS)						
Mark	BRAND	DESCRIPTION	MODEL	BTU	FUEL	UTILITY CONNECTIONS
1	JACKSON	34" LUX GRILL C/W 4 BURNERS & ROTISSERIE	JLS700BI	73,500	NATURAL GAS	GAS & ELEC

CLADDING PRODUCT INFO:
 MANUFACTURER: COSENTINO
 MATERIAL: (8mm) DEKTON (TO BE DETERMINED)
 COUNTERTOP PRODUCT INFO:
 MANUFACTURER: COSENTINO
 MATERIAL: (20mm) DEKTON (TO BE DETERMINED)
 LOCAL SUPPLIER: CANADA OUTDOOR KITCHENS

INSERT CABINET PRODUCT INFO:
 MANUFACTURER: JACKSON
 PANEL COLOR: STAINLESS STEEL
 MATERIAL: STAINLESS STEEL
 LOCAL SUPPLIER: CANADA OUTDOOR KITCHENS

DRAWING APPROVAL

APPROVED

APPROVED AS CORRECTED

DRAWING MUST BE APPROVED & SIGNED PRIOR TO FABRICATION & SHOP DRAWINGS

SIGNATURE:

DATE:

*DEKTON IS PRODUCED UNDER HIGH HEAT & PRESSURE. NATURAL FISSURES MAY BE EXPECTED



DRAWN: D. BENNETT

EMAIL: darcy@bennettpollio.com

SCALE: 1/4" = 1'-0"

DATE: 10/21/20

PROJECT: GRILL KIT

QUOTE #: TuClad

A4

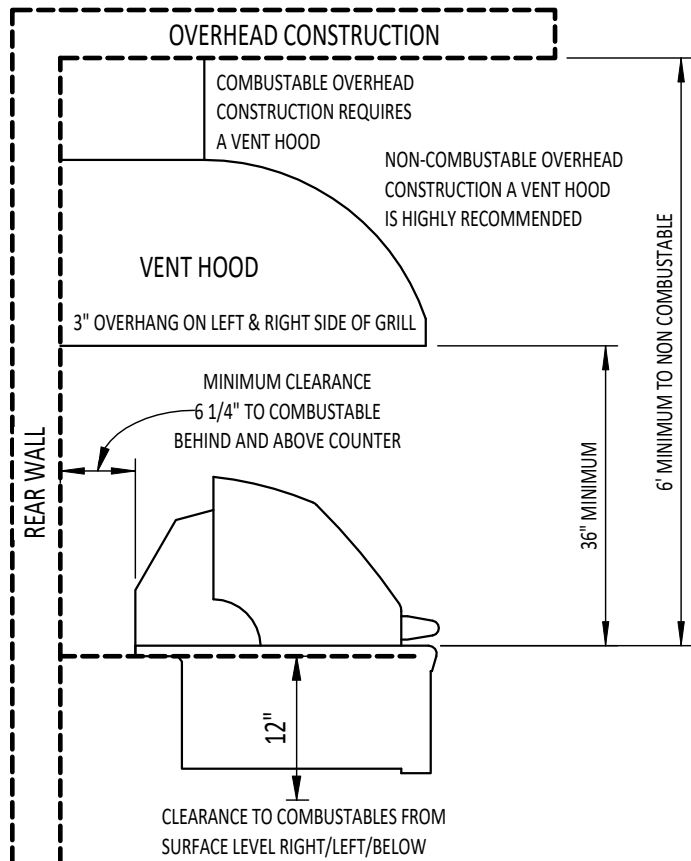

1 VENT HOOD INFO

OVERHEAD PROTECTION AND EXHAUST REMOVAL.

VENTING SPECIFICATION **MUST BE IN THE GRILL MANUAL.**

IF GRILL IS INSTALLED UNDER ANY COMBUSTIBLE CONSTRUCTION, THE COOKING AREA OVER THE GRILL MUST BE COVERED WITH AN EXHAUST HOOD.

IF INSTALLED UNDER ANY COVER, COMBUSTIBLE OR NON-COMBUSTIBLE, SHARING A VENTED ATTIC SPACE WITH THE DWELLING. THE COOKING AREA OVER THE GRILL MUST BE COVERED WITH AN EXHAUST HOOD TO PREVENT MIGRATION OF CARBON MONOXIDE GAS.

EXHAUST HOOD SHALL PROVIDE NO LESS THAN 1,200 CFM FOR PROPER EXHAUST VENTILATION. THE HOOD MUST BE APPROVED FOR OUTDOOR USE AND PROVIDED WITH A DEDICATED GFCI PROTECTED BRANCH CIRCUIT.

MINIMUM CLEARANCE FROM SIDES AND BACK OF GRILL TO ADJACENT COMBUSTIBLE CONSTRUCTION BELOW THE COUNTERTOP SURFACE IS 12" FROM THE SIDES AND 6 1/4" FROM THE BACK OF THE HOOD.

MINIMUM CLEARANCE FROM SIDES AND BACK OF GRILL TO ADJACENT COMBUSTIBLE CONSTRUCTION EXTENDING ABOVE THE COUNTERTOP SURFACE IS 12" FROM THE SIDES AND 6 1/4" FROM THE BACK.

THE HOOD MUST PROVIDE 3-6 INCHES OF OVERHANG ON ALL EXPOSED SIDES.

ABOVE SPECIFICATION IS FROM THE LYNX & SEDONA GRILL MANUALS.



DRAWN: D. BENNETT

EMAIL: darcy@bennettpollio.com

SCALE: As indicated

DATE: 10/21/20

PROJECT: GRILL KIT

QUOTE #: TuClad

A5